

Clamp arms *for swing cylinders*

Shown: CAL-122, CAS-121



▶ Clamp arms are used to transmit the force generated by the swing cylinder to the workpiece. Enerpac's patented clamp arm design attaches to the hydraulic swing cylinder, allowing parts to be clamped at various distances from the hydraulic cylinder. Clamp arms are available in a variety of lengths, or you can use custom machining dimensions to create your own clamp arm configuration.

■ Hydraulic fixture with swing cylinders and standard clamp arms on two faces for more efficient production.



Patented Design

- Easy and precise location of the clamp arm in any position
- Arm can be easily installed and fastened while the cylinder is mounted in the fixture to allow exact arm positioning
- Vise not required for fastening arms

Pressure vs clamping force

The use of different length clamp arms requires reduction in applied pressure and resulting clamp force. The diagrams on page 10 below show this relationship.

Product selection

Clamp arm length L mm min. - max.	Clamping force F _T kN max. - min.	For Swing Cylinder Model	Clamp Arm Model number	See Diagram on page	Technical Specifications on page
▼ Swing Cylinders SU, SL, ST and SC series					
20 - 60	1,3 - 0,3	11	CAS-11, CAL-11	11	25
25 - 78	2,2 - 0,5	22	CAS-22, CAL-22	11	25
40 - 130	5,6 - 1,0	52	CAS-52, CAL-52	11	25
45 - 155	9,0 - 2,2	92	CAS-92, CAL-92	11	25
51 - 157	11,6 - 2,0	121, 122	CAS-121, CAL-122	11	25
55 - 173	18,7 - 4,0	202	CAS-202, CAL-202	11	25
68 - 175	33,8 - 9,0	352	CAS-352, CAL-352	11	25
▼ Collet-Lok® Swing Cylinders MP series					
40 - 100	4,1 - 1,1	50	MA-540	11	25
50 - 125	8,9 - 2,5	100	MA-1050	11	25
70 - 160	37,8 - 9,5	300	MA-3070	11	25
▼ Pivoting T-arms for SU, SL, ST and SC series swing cylinders					
152 ¹⁾	2 x 2,8	52	CAC-52, CAPT-52	11	26
203 ¹⁾	2 x 4,5	92	CAC-92, CAPT-92	11	26
203 ¹⁾	2 x 5,8	122	CAC-122, CAPT-122	11	26
203 ¹⁾	2 x 9,3	202	CAC-202, CAPT-202	11	26
228 ¹⁾	2 x 16,9	352	CAC-352, CAPT-352	11	26

¹⁾ Lmax. for T-arms.



CAS models Standard clamp arms

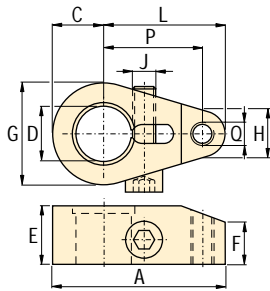

CAL models Long clamp arms

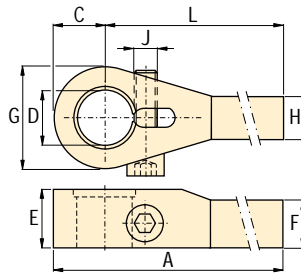

MA models For Collet-Lok® Swing cylinders serie MP

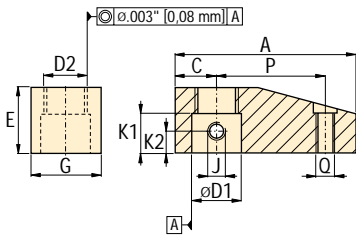

Custom design (for SU, SL, ST and SC models only)

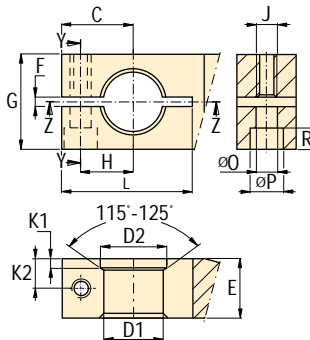

Dimensions in mm [mm]

Clamp force kN	Model number	A	C	D	E	F	G	H	J	L	P	Q	kg
----------------	--------------	---	---	---	---	---	---	---	---	---	---	---	----

Standard clamp arms

1,3	CAS-11	33	7,6	7,95-8,05	12	7	15	10	#10-32UNF	25	20	#10-32UNF	0,1
2,2	CAS-22	41	9,7	9,95-10,05	16	10	19	13	M6x1	31	25	M6x1	0,1
5,6	CAS-52	61	12,7	15,95-16,05	19	11	25	16	M8x1	48	40	M8x1,25	0,4
9,0	CAS-92	76	20,1	24,94-25,04	25	16	40	23	M10x1,25	56	45	M10x1,5	0,3
11,6	CAS-121	80	17,8	22,17-22,27	30	16	35	21	.375-24UNF	62	51	.375-16UN	0,5
18,7	CAS-202	94	24,1	31,93-32,03	30	21	48	30	M12x1,25	70	55	M12x1,75	0,5
33,8	CAS-352	118	35,1	37,95-38,05	40	29	70	31	M16x1,5	83	68	M16x2	1,4

Long clamp arms

1,3	CAL-11	72	7,6	7,95-8,05	12	8	15	9	#10-32UNF	65	-	-	0,1
2,2	CAL-22	92	9,7	9,95-10,05	16	10	19	11	M6x1	83	-	-	0,1
5,6	CAL-52	148	12,7	15,95-16,05	19	11	25	14	M8x1	135	-	-	0,5
9,0	CAL-92	180	20,1	24,94-25,04	25	16	40	18	M10x1,25	160	-	-	0,6
11,6	CAL-122	179	17,8	22,17-22,27	30	16	35	18	M10x1,5	162	-	-	0,7
18,7	CAL-202	202	24,1	31,93-32,03	30	21	48	25	M12x1,25	178	-	-	0,7
33,8	CAL-352	215	35,1	37,95-38,05	40	34	70	30	M16x1,5	180	-	-	1,9

Clamp force kN	Model number	A	C	D1	D2	E	G	J	K1	K2	P	Q	kg
----------------	--------------	---	---	----	----	---	---	---	----	----	---	---	----

Clamp arms for Collet-Lok®

4,4	MA-540	72	18	19,02-19,05	M16x1,5	30	32	M8x1,25	19	10	40	M8x1,25	0,5
8,9	MA-1050	83	19	22,30-22,33	M20x1,5	30	35	M8x1,25	18	10	50	M10x1,5	0,5
37,8	MA-3070	128	35	34,97-35,00	M33x2	47	59	M8x1,25	32	17	70	M16x2	2,3

Clamp force kN	C	D1 ¹⁾	D2	E	F	G	H	J	K1	K2	L	O	P	R
----------------	---	------------------	----	---	---	---	---	---	----	----	---	---	---	---

Custom design clamp arms ²⁾ (Recommended machining dimensions)

1,3	15,5	7,95-8,05	9,83-9,88	12	2,0-3,0	15	7,6	#10-32UNF	2,5-3,0	8	21-24	5,7	10	2
2,2	15,5	10,00-10,02	12,58-12,62	16	1,5-3,0	20	9,4	M6x1	3,1-3,5	8	25-28	7,0	12	2
5,6	20,1	16,00-16,03	18,47-18,51	19	1,5-3,0	30	13,5	M8x1	4,1-4,5	10	35-40	9,0	13	2
9,0	30,0	25,00-25,03	27,85-27,95	25	1,5-3,0	40	22,1	M10x1,25	3,9-4,2	12	55-60	10,0	17	2
11,6	28,4	22,24-22,27	25,46-25,55	30	1,5-3,0	35	17,8	M10x1,5	6,9-7,3	13	52-57	10,0	17	3
18,7	35,1	32,00-32,04	35,50-35,60	30	1,5-3,0	60	24,9	M12x1,25	5,1-5,5	15	62-67	13,0	19	3
33,8	39,9	38,00-38,04	41,50-41,60	40	1,5-3,0	70	30,0	M16x1,5	4,9-5,3	20	80-85	17,0	25	4

¹⁾ Surface roughness for D1 should be 1,6 micrometers.

²⁾ Not for use with Collet-Lok® cylinders.

Force: 1,3 - 37,8 kN

Pressure: 35 - 350 bar

- E** Brazos de amarre
- F** Bras de bridage
- D** Spannarme

Options

Gauges

128 ▶



Flow control valves

112 ▶



Important

Do not exceed maximum oil flow

If flow rates are exceeded, swing cylinder indexing mechanism may be permanently damaged.

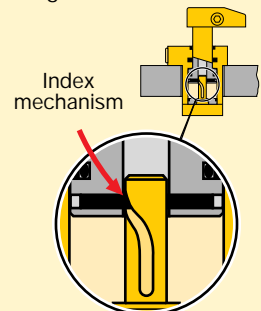

When designing custom clamp arms, the flow rates must be further reduced. This rating should be in proportion to the mass and the centre of gravity of the clamp arm.

Example:

If the mass of the arm is twice that of the long arm, flow rates must be reduced by 50%.